



KOMAS

Opava •

Czech producer

AUTOMOTIVE

TOOL SHOP

FITTINGS

**ELECTRICAL
INDUSTRY**

Komas history and present time

- Originally Komas Ltd. has been a part of Brano company and after privatization in 1991 had KOMAS five owners.
- In November 2016 was KOMAS bought by a new owner Mr. Rudolf Bochenek, who is 100% owner of all companies, which are members of BR Group.
- **We are specialist for transfers of the running project, we still to try to bring quality and added value for the customer.**
- The tool shop products all necessary stamping tools (progresive and one step tool) including quick maintenance of tools.
- KOMAS turnover is devided as below:
 - 40% automotive
 - 13% electroindustry
 - 27% tool shop
 - 20% building fittings

KOMAS is member of BR Group

Total turnover of BR Group companies in 2017 was 124,2 mil. EUR

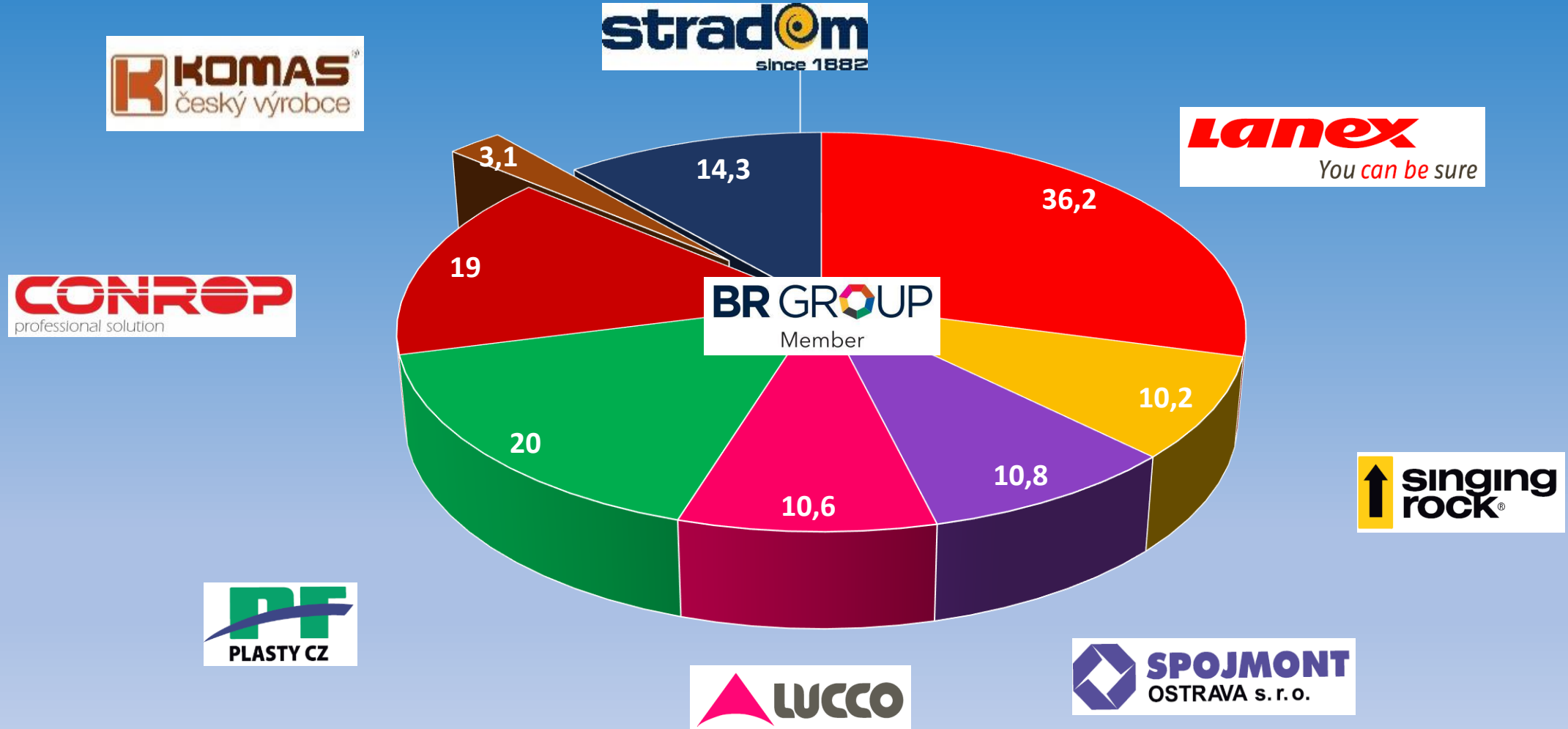

Key KOMAS customers

BENTELER 
makes it happen

ŠKODA



Continental 



OEZA 

 **Robertshaw**

EATON

Production capacities and possibilities

- Stamping by mechanical presses till 160T and by progressive presses Heilbronn 250Tonne and 320T, from August 2018 progressive press line SIMPAC 500T
- Production and maintenance of stamping tools, **Tool shop in Komars.**
- Machining and assembly – turning, milling, grinding, drilling, riveting
- Welding equipment – welding presses LE 100T, LE 160T and LE 200T
- Surface treatments – degreasing, painting, phosphating
- Packing of products acc. to customers requirements

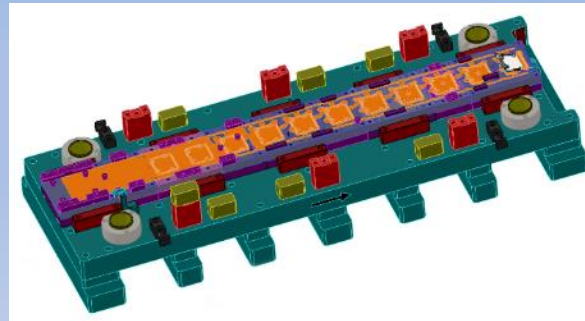

Stamped parts

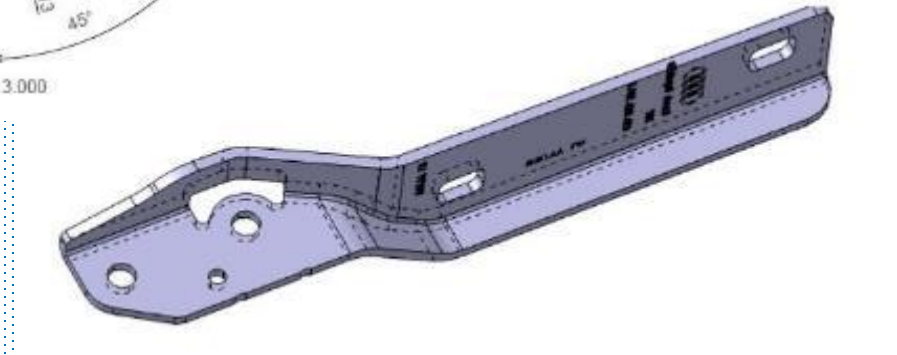
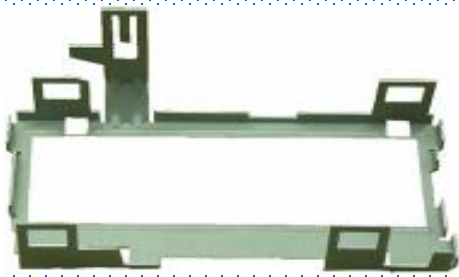
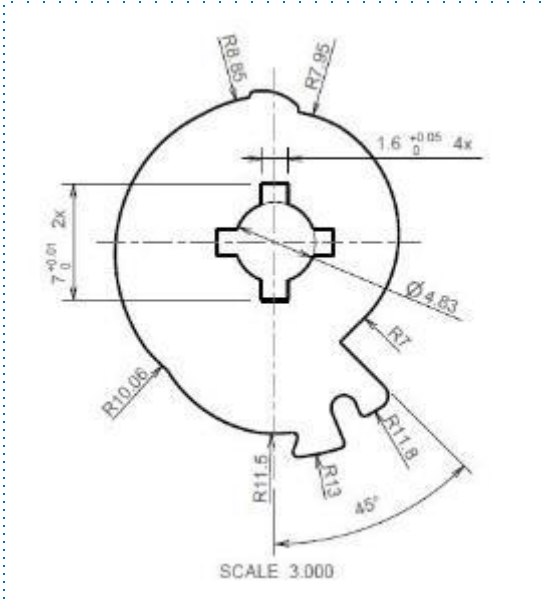
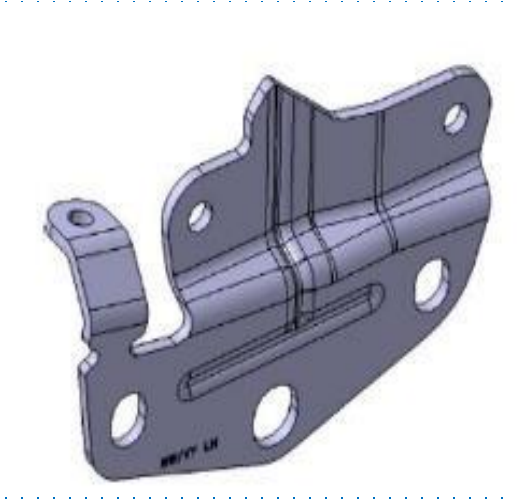
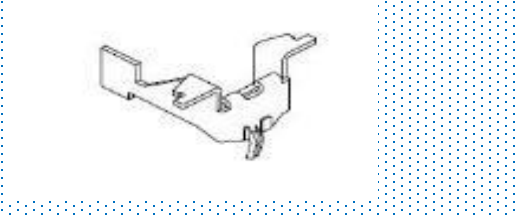
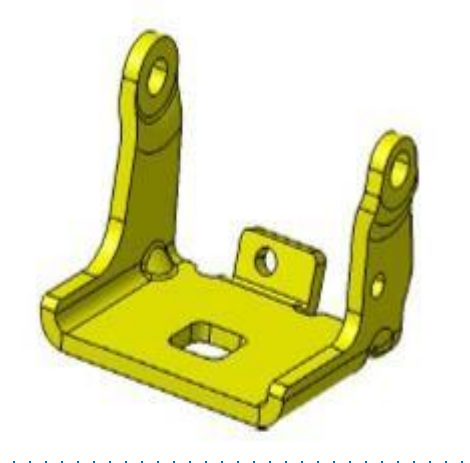
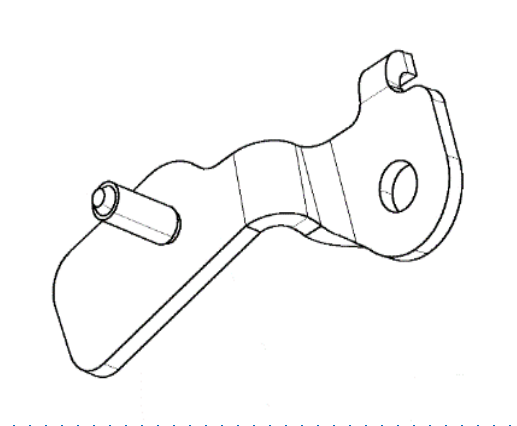

Research and Development

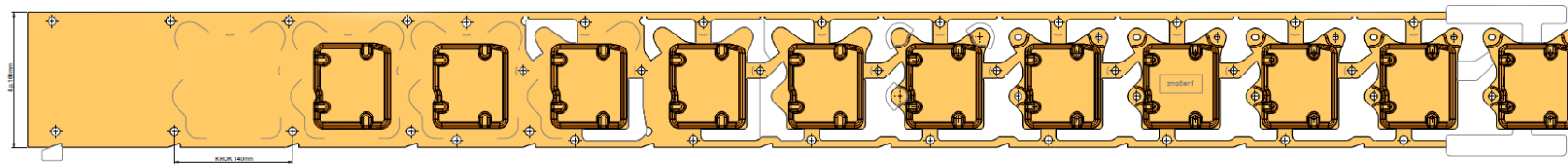
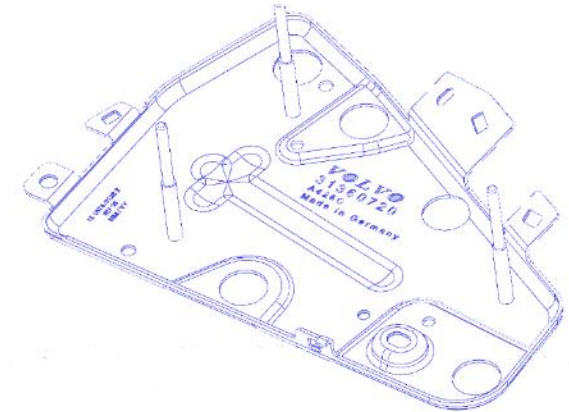
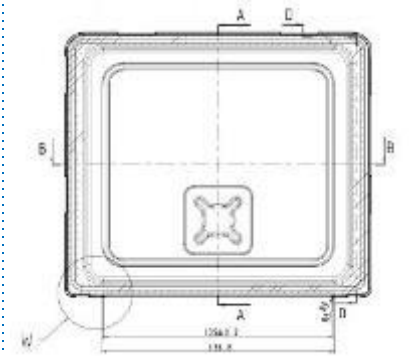
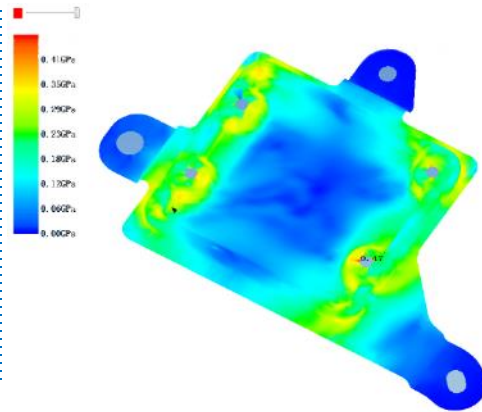
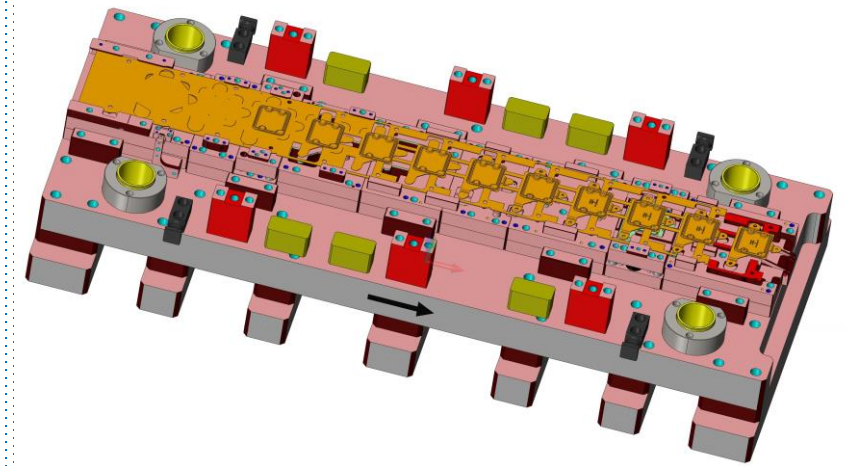
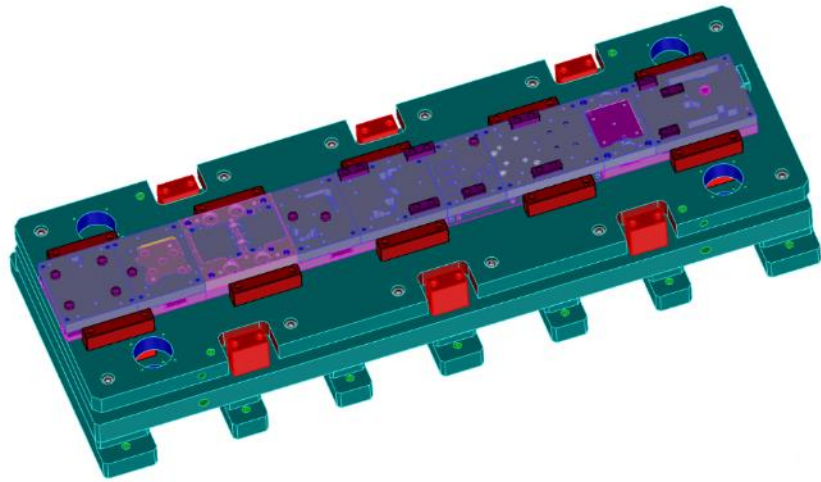

New production workshop – Heilbronn 250t and 320t



In this workshop are available 2 progressive presses Heilbron 250t and 320t and 1 progressive press SIMPAC 500t from August 2018. This tempered workshop is ready for increase of production capacities.

New progressive press line SIMPAC 500T



Pressing force of mechanical progressive press SIMPAC is 500t, stroke per minutes (SPM) 20-40, adjustable height of the tool 250mm, slide dimension 3.200x1400mm, Material: steel / Al, Material thickness: 0.6-6mm, Coil width: 200-600mm, Max. coil weight 5t

Degreasing equipment –Dürr Compact 80C



KOMAS has a new degreasing equipment Dürr Compact 80 C based on hydrocarbon. This technology is environmentally friendly, process of degreasing is vakuum closed.

CNC 3D measuring equipment Wenzel LH 108



Measuring of products is realized by measuring equipment CNC 3D WENZEL LH 108. Measuring is made by KOMAS qualified employees acc. to drawings or 3D model.

Electroerosive wire cutting



KOMAS is able to cut products by electroerosive wire cutting technology CNC FANUC Robocut equipment.

Three axes CNC milling machines



Machining of products is made by CNC machining automat MCV 1000 SPEED and MCV 750 SPEED acc to customer's drawings.

Tumbling



We are able to solve a huge range of technological requirements by tumbling technology. For instance treatment of sharp edges and burrs, polishing and smoothing of surface, degreasing, cleaning and removing of rust.

KOMAS QMS CERTIFICATION



THE INTERNATIONAL CERTIFICATION NETWORK

CERTIFICATE

DQS Holding GmbH has issued an IQNet recognized certificate that the organization

KOMAS, spol. s r.o.
Ostravská 33
747 70 Opava - Komárov
Czech Republic

has implemented and maintains a **Quality Management System**.

Scope:
Manufacturing of stamping, welded and assembled metal parts

Through an audit, documented in a report, it was verified that the management system fulfills the requirements of the following standard:

ISO 9001 : 2015

Issued on: 2018-05-23
Expires on: 2021-05-22

This attestation is directly linked to the IQNet Partner's original certificate and shall not be used as a stand-alone document.

Registration number: DE-271445 QM15



Alex Stoichitoiu
President of IQNet

Michael Drechsel
Managing Director of
DQS Holding GmbH



IQNet Partners:
AENOR Spain AFNOR Certification France APCER Portugal CQC Cyprus CISO Italy
CQC China IQM China CQS Czech Republic Cro Cert Croatia DQS Holding GmbH Germany FCAV Brazil
FONDONORMA Venezuela ICONTEC Colombia Inspecta Certificanti Oy Finland INTECO Costa Rica
IRAM Argentina JQA Japan KFO Korea IMRTEC Greece MSZT Hungary Nemko AS Norway NSAI Ireland
NYCE-SICE Mexico PCB Poland Quality Austria Austria RIR Russia SII Israel SIO Slovenia
SIRIM QAS International Malaysia DQS Switzerland SRAC Romania TEST Petersburg Russia TSE Turkey YUGS Serbia
IQNet is represented in the USA by: AFNOR Certification, CISO, DQS Holding GmbH and NSAI Inc.

* The list of IQNet partners is valid at the time of issue of this certificate. Updated information is available under www.iqnet-certification.com.



CERTIFICATE



This is to certify that

KOMAS, spol. s r.o.
Ostravská 33
747 70 Opava - Komárov
Czech Republic

has implemented and maintains a **Quality Management System**.

Scope:
Manufacturing of metal parts

An audit, conducted and documented in a report, has verified that this quality management system fulfills the requirements of the following International Automotive Standard:

IATF 16949:2016
(without product design)

Certificate registration no.	271445 IATF16
Issuing date	2018-05-23
This certificate is valid until	2021-05-22
IATF No.	0307269



2-IAO-QMC-01001

For and on behalf of DQS

Nuran S. Venkatchaam
Corporate Program Manager Automotive, DQS Holding GmbH

Michael Drechsel
Managing Director, DQS Holding GmbH

IATF Contract Office: DQS Holding GmbH, Konrad-Adenauer-Allee 9-10, 61118 Bad Vilbel, Germany

2017-10-09

KOMAS is certified ISO 9001 and IATF 16949.

OHSAS and EMS CERTIFICATION

CQS - Sdružení pro certifikaci systémů jakosti
Pod Lisem 129, 171 02 Praha 8 - Troja
Česká republika

CQS je certifikačním sdružením, akreditovaným podle normy ČSN EN ISO/IEC 17021-1:2016 Českým institutem pro akreditaci, s.p. pod registračním číslem 3029 pro certifikaci systémů managementu bezpečnosti a ochrany zdraví při práci



CERTIFIKÁT

Číslo: CQS 244/2016

CQS - Sdružení pro certifikaci systémů jakosti na základě kladného výsledku certifikačního auditu prohlašuje, že systém managementu bezpečnosti a ochrany zdraví při práci



KOMAS, spol. s r.o.
Ostravská 291/33, Komárov, 747 70 Opava, Česká republika

byl prověřen a shledán v souladu s požadavky

ČSN OHSAS 18001 : 2008

Tento certifikát platí pro procesy:

- Nákup, výroba a prodej dveřních a okenních usazení, uchytné dvířko a okenního kování, bezpečnostní a dvířko kování, doplňky vnitřního dvířka a okenního kování, bezpečnostní kování, nábytkového kování, lanových sponek
 - Technická příprava a výroba, výroba a prodej usazení pro automobilový průmysl
 - Nákup, výroba, výroba a prodej náročná, příslušenství a protáčení kovoviny
 - Nákup, výroba, výroba a prodej usazení s mechanickým pohonem
- Koupě zboží za účelem jeho dalšího prodeje a prodej při oblékání a sestavení a okenního závěsného kování, bezpečnostního kování, nábytkového kování, lanových sponek, komponentů pro zástrčkové přístroje, a šperky, příslušenství a produktů kovové výroby, strojů a strojních prvků

Platnost certifikátu omezena do: 02. 12. 2019
Rozhodnutí o certifikaci: 03. 12. 2016
Datum vydání: 03. 12. 2016
Datum udělení prvního certifikátu: 30. 12. 2008





Ing. Jana Ošlanská
 Vedoucí certifikačního orgánu



Členové CQS
Elektrotechnický zkušební ústav, s.p., Fyzikálně-technický zkušební ústav, s.p., Institut pro testování a certifikaci, s.p.,
Strojrenský zkušební ústav, s.p., Technický a zkušební ústav stavební Praha, s.p., Textilní zkušební ústav, s.p.,
* Seznam členů CQS včetně adres vydání certifikátů. Aktuální seznam je k dispozici na www.cqs.cz.

CQS z.s.
Prosecká 412/74, 190 00 Praha 9 - Prosek
Czech Republic

CQS is the Certification Body No 3029 accredited according to Standard EN ISO/IEC 17021-1:2015 by the Czech Institute for Accreditation for the Certification of Management Systems



CERTIFICATE

No.: CQS 243/2016

CQS certifies that the Environmental Management System of



KOMAS, spol. s r.o.
Ostravská 291/33, Komárov, 747 70 Opava, Czech Republic

has been assessed and found to be in conformity with the requirements of

EN ISO 14001: 2015

with respect to the following processes:

- Design, development, production and distribution door and window closure, upper door and window fittings, safety fittings, accessories door and window fittings, box fittings, furniture fittings, rope clamp
- Technical production preparation, production and distribution components for automotive industry
 - Design, development, production and distribution tools, devices and metal production
 - Design, development, production and distribution machine with mechanic drive
- Buying goods for purpose next sale and sale for sphere door and window building fittings, box fitting, furniture fittings, rope clamp, components for automotive industry, tools, devices and metal production, machine with mechanic drive

The certificate is valid until: 02. 12. 2019
Certification decision: 03. 12. 2016
Date of issue: 03. 12. 2016
Date of change: 29. 12. 2017
Date of granting the first certificate: 12. 11. 2007





Jana Ošlanská
 Managing Director



CQS Members*
Elektrotechnický zkušební ústav, s.p., Fyzikálně-technický zkušební ústav, s.p., Institut pro testování a certifikaci, s.p.,
Strojrenský zkušební ústav, s.p., Technický a zkušební ústav stavební Praha, s.p., Textilní zkušební ústav, s.p.,
*A CQS member list valid at the time of issue of the certificate. Current list is available at www.cqs.cz.

Company management

- **Chief executive officer:** Marek Kloupar
- **Financial director:** Erich Kučera
- **Sales director:** Juraj Svoboda
- **Quality assurance director:** Martin Amort
- **Head of Tool plant:** Michael Benek
- **Production manager:** Daniel Konečný
- **Technical manager:** Jiří Choleva
- **Purchasing manager:** Jiří Lerche

Contact persons

Juraj Svoboda
Sales Manager

svoboda@komas.cz
mobil: +420 734 281 656
www.komas.cz

Klára Stříbná
Project manager -
automotive

stribna.klara@komas.cz
tel.: +420 553 607 354
fax: +420 553 607 365
mobil: +420 603 180 377
www.komas.cz

Jiří Petr
Building fittings

petr.jiri@komas.cz
tel.: +420 553 607 366
fax: +420 553 607 365
mobil: +420 731 173 235
www.komas.cz

Thank you for
attention.

www.komas.cz